



Brigade

Select Monitors – Troubleshooting Including Locked, Blue Screen Issues

Version 1.0 - A. Scott

Overview

- “Locking” and “unlocking” a Select Monitor.
- Blue Screen/No Signal, Troubleshooting.
- Unresponsive Buttons Troubleshooting.
- Monitor Not turning On.

Button Identification

Brigade



- (Power) Button
- (OK) Button
- (Menu) Button
- (Up) Button
- (Down) Button

Locking and Unlocking a Select Monitor

One of the most common calls Technical Support receives is how to “Unlock” or “Lock” the buttons on the right side of the Select Monitor”.



Locking and Unlocking a Select Monitor



- Simply hold down the menu for 20 seconds and the Monitor will display (“unlocked”) on the screen.
- Holding the menu button down for another 20 seconds will “re-lock” the Monitor.

Note: Sometimes 20 seconds can feel a lot longer than it actually is, so this will require patience.

Blue Screen/No signal, Troubleshooting.

It is often reported that the Monitor is faulty because it is displaying a blue screen with (No Signal) in the centre.

This is in fact **not** an issue with the Monitor, but an issue with either the camera, the connections or cabling between the camera or MDR connected to the Monitor.



Blue Screen/No signal, Troubleshooting.

A blue screen indicates there is no video signal going to the selected channel of the Monitor therefore we recommend.

- Check the correct channel is selected.
- Check the camera cable connections are tight and clean.
- Check the camera cables for damage.
- Check the camera itself is working correctly.



Check the Correct Channel is Selected



- Simply press the (OK) button to shuffle between each camera channel.
- Note: The Monitor will need to be unlocked to do this.

Points & Connections to Check

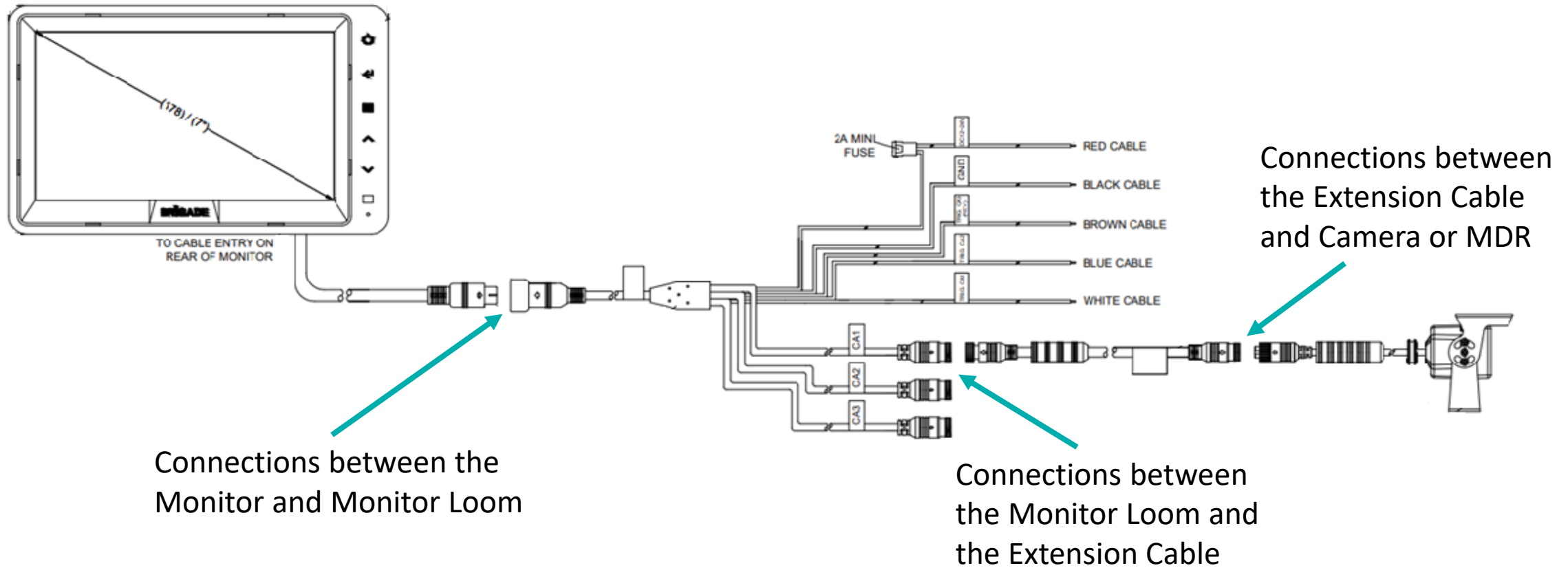

Unresponsive Buttons



If the buttons on the right-hand side of the Monitor are unresponsive or only partially working, this could be a result of the natural grease and oils from our fingers building up over the soft touch buttons.

We recommend thoroughly cleaning the area over the buttons with a non-alcoholic wipe and leaving it to dry naturally.

If this does not solve the issue it may be a faulty Monitor.

Monitor Not Turning On

If a Monitor will not turn on, this does not always mean that the Monitor is faulty. There are several tests we can perform to identify if the Monitor is faulty or if there is another cause to why the Monitor will not turn on.

- Check the Fuse.
- Check to see if the Monitor is getting Power.
- Check to ensure the Monitor is sufficiently Grounded.



Monitor Not turning On

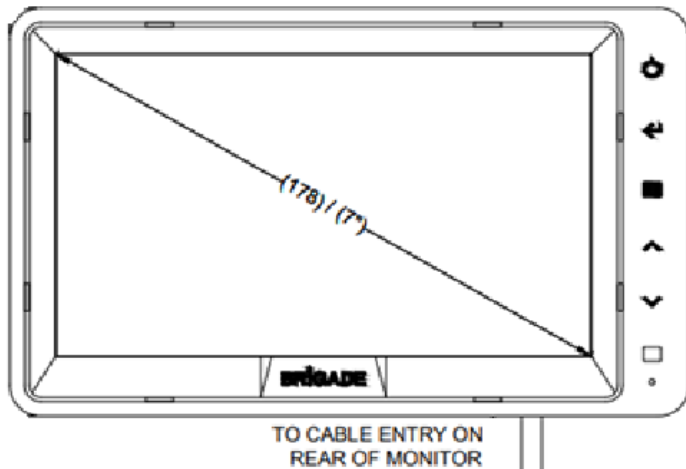

The first thing to check would be the Fuse on the red power input cable. If this has blown, then the Monitor will not receive any power.

Replacing the Fuse should Solve this issue.

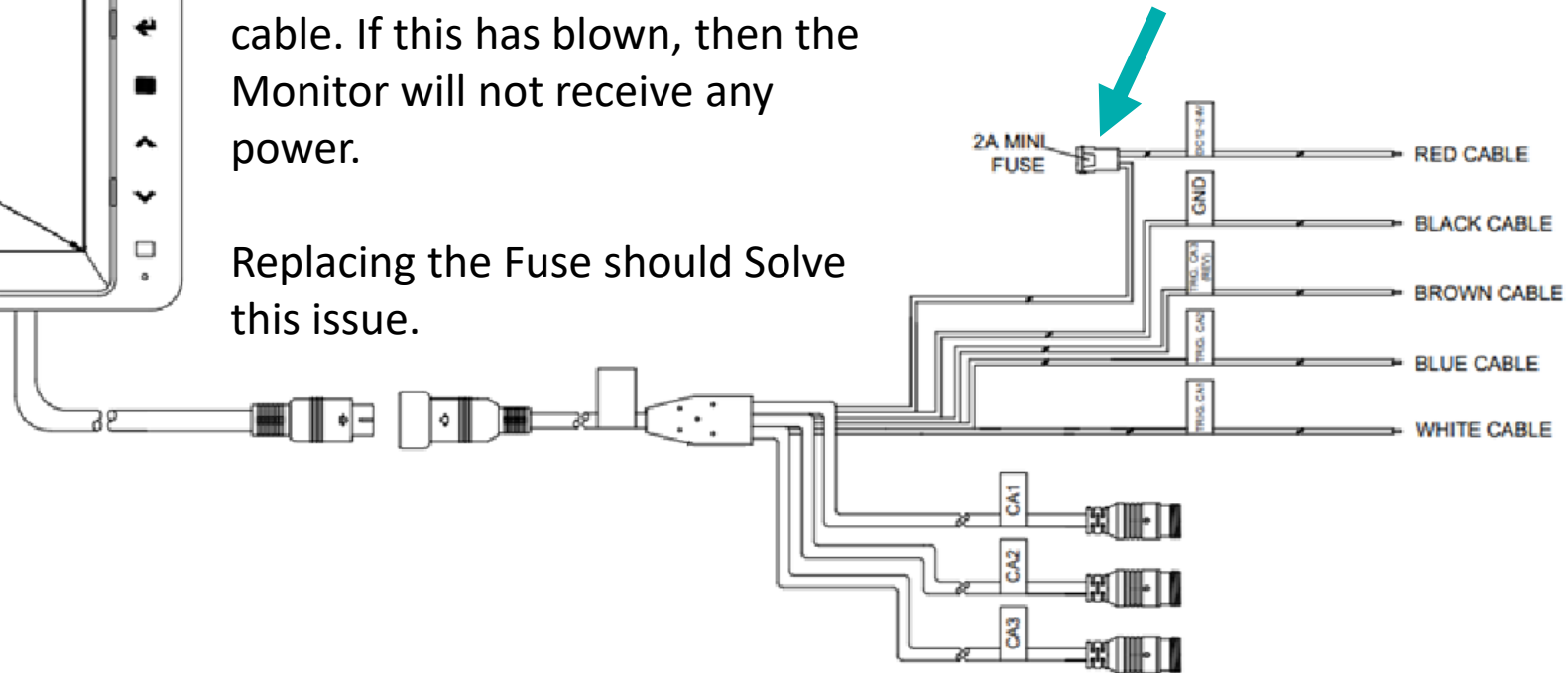

Monitor Not Turning On

Next you will need to check that the Monitor is receiving 12-24 volts to the red cable. This can be done using a multi-meter.

If there is no power going to the red cable, then the solution would be to create a new power feed to the red cable.

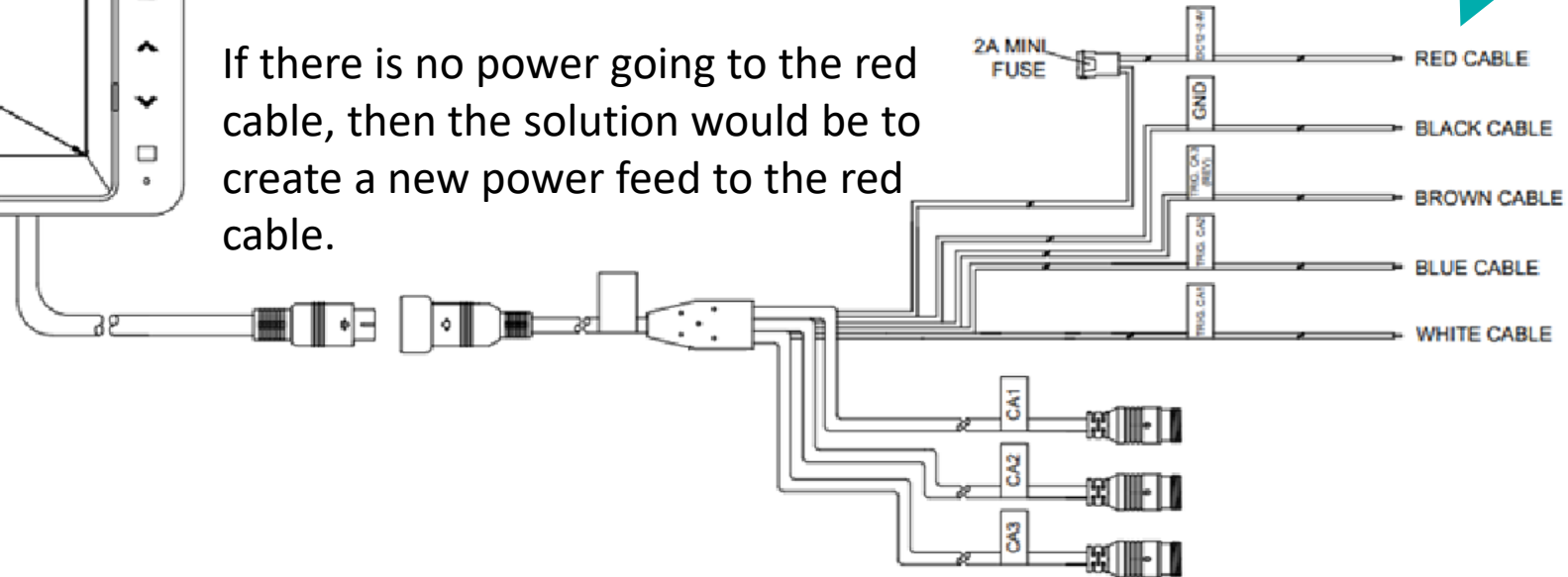
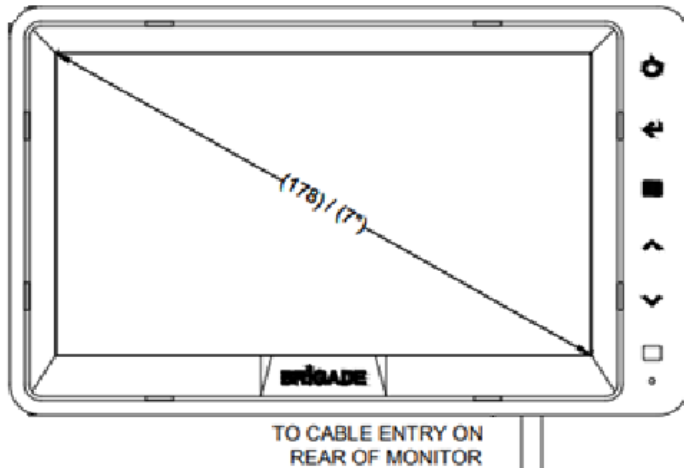

Monitor Not Turning On

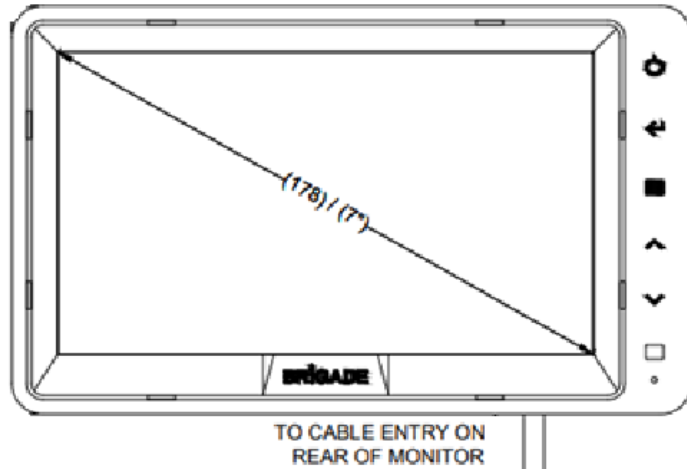

Lastly you will need to ensure that the Monitor is sufficiently Grounded.

This is done by using a multi-meter and doing a continuity test.

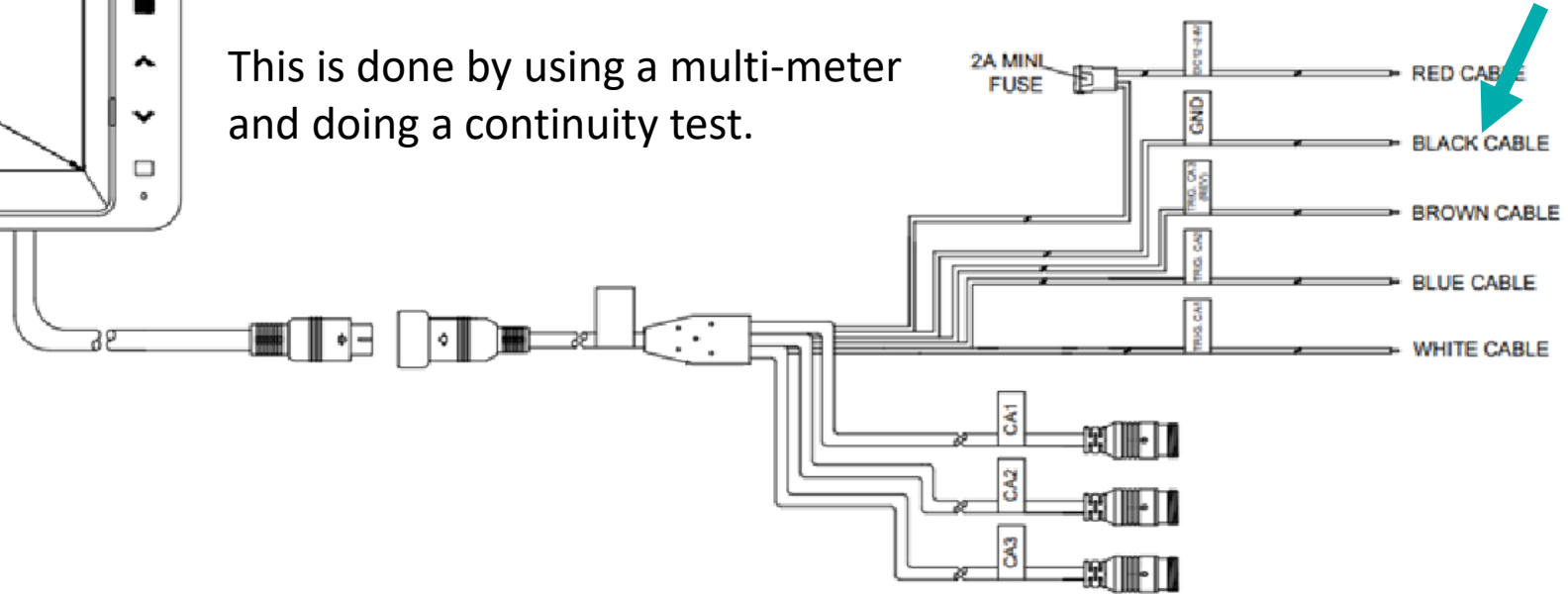

Monitor Not turning On

If none of these solution work, then it is likely that the monitor is likely faulty and will need replacing.



Contact Us

Brigade Electronics Group Plc.

Brigade House, The Mills, Station Road

South Darenth, Kent DA4 9BD, United Kingdom

Sales and Customer Services: +44 (0) 1322 420300

Technical Support: +44 (0) 1322 420347

www.brigade-electronics.com